

CCBB & CCBB II

# *Bandsaw*

User Manual



*Perform*



Order No. CCBB

CCBB &  
CCBB II

**Bandsaw**



*Perform*

CCBB & CCBB II

## Index of Contents

	Page No.
Declaration of Conformity.....	2
What's in the Box.....	3
General Instructions for 230v Machines.....	3,4
Initial Assembly.....	5,6,7
Machine Specifications.....	8
Identification and Description of the parts of the Saw.....	8
Machine Illustration and Parts Description.....	9
Identification and Description of the parts of the Saw (Continued).....	10
Machine Illustration and Parts Description (Continued).....	11
Illustrated Parts Breakdown (Assembly Diagram).....	12,13
Illustrated Parts Catalogue (Band Saw)Part 1.....	14
Illustrated Parts Catalogue (Band Saw)Part 2.....	15
Identification and Description of the parts of the Saw (Continued).....	16
Machine Illustration and Parts Description (Continued).....	17
Machine Illustration and Parts Description (Continued).....	18
Machine Illustration and Parts Description (Continued).....	19
Setting up the Saw.....	20
Setting up the Saw (Continued).....	21
Operating Instructions.....	22
Operating Instructions (Continued).....	23
Changing the Saw Blade.....	23



## Declaration of Conformity

The undersigned, K. Ehret authorised  
by Shandong Laizhou Industrial Sewing Machine  
Factory No: 275 Wen Quan East Road, Laizhou,  
Shandong 261400  
P.R. China  
declares that this product:

**Wood Cutting BandSaw**  
**MJ343B,MJ343C**  
( Serial no: FL23150919,FL23150919)

manufactured by Shandong Laizhou Industrial  
Sewing Machine Factory is in compliance with the  
following standards or standardisation documents  
**EN 55 014:1993, EN 61000-3-2:1995**  
**EN 61000-3-3:1995, EN 55 014-2:1997**  
in accordance with Council Directives, 98/37/EC

## Operating Instructions (Continued)

13. Do not release the tension on the saw blade when work is complete. The blades and the main saw frame do not respond kindly to constant changes in stress and tension. Only release the tension to change the blade or if the blade is to be removed because the machine is to be 'mothballed' for a lengthy time period. (The blade in tension over a long period of non-use will cause the tyres to develop 'flat' spots).



**N.B. IF THE SAW JAMS! Switch off immediately. Open the saw cut, either by pulling apart or driving a wedge in close to the back of the blade. Try to wriggle the blade free of the saw, if this is not possible; check that the saw is free in the cut, start the saw, allow it to run up to speed and 'cut out' as quickly as possible. (The removal of the 'offcut' may well prevent the saw jamming again if you resume the original cut).**

## Changing the Saw Blade

### MAKE SURE THE SAW IS DISCONNECTED FROM THE SUPPLY.

Put the table back to the level position if it has been tilted. Set the upper blade guide assembly approximately midway in the throat. Open the top and bottom covering doors. Remove the table insert. Loosen the 4 butterfly bolts that hold the fence guide rail to the table, and remove the rail. Slacken the blade tension by turning the blade tensioning wheel anti-clockwise, until the blade can be easily slipped off the wheels. Remove the blade carefully, "wriggling" it clear of the upper blade guard and through the red plastic lower blade guard and out through the slot in the table. NOW is an excellent time to clean out the interior of the machine, remove the impacted 'crud' from the tyres, apply a little light oil to the screw threads of the blade and drive belt tensioners, and the tracking control. The pivots and the slides of the top wheel mounting assembly and the captive stub axle of the drive belt tensioner in its slot could likewise be lightly oiled. If you are fitting a new blade; it will have been supplied to you "folded", bound together in this configuration with tape or tie wrap. Be very cautious when you "unfold" the blade; it tends to 'spring' open, blade and teeth going everywhere.

Also check that the blade did not "unfold" inside out. i.e. looking at the right side front of the loop, the teeth should be on the front of the blade, and pointing down. If you can't arrive at this view, turn the blade inside out from its current position and look again. Hold the blade approximately midway on either side of the loop and feed it into the table slot, when you get to the table insert cutout void, work the left side of the loop into the slot in the guard in the neck of the main saw frame. "Wriggle" the righthand side of the blade through the slot in the red plastic lower guard and through the guard on the upper blade guide assembly. Ease the blade over the wheels, and locate the blade in the blade guides. Apply some tension to the blade. Turn the top wheel by hand to ensure the blade will not skip off the wheels and the blade is travelling in the blade guides. Apply a little more tension and check again by once again spinning the upper saw wheel by hand. When you are sure that the blade is "ON" and stable, re-fit the fence guide rail, re-fit the table insert and carry out the procedures as detailed in **Setting up the saw.**

## Operating Instructions



### MAKE SURE THE SAW IS DISCONNECTED FROM THE SUPPLY.

1. Make sure you have read and fully understood the General instructions and safety precautions that are printed in the preceding pages of this manual.
2. Before connecting the machine to the supply; check the tool for obvious signs of damage, paying particular attention to the plug and the power cable. Rectify or have rectified any damage you discover. Check that the blade you are using is the correct one for the job in hand. Change the blade if necessary. Check the blade is not damaged; is clean, sharp, tracks properly and is correctly tensioned.
3. Set the upper blade guide to approximately 12mm (1/2") above the height of the workpiece.
4. Check (especially on site), that there are no foreign objects e.g. old nails, screws, small stones etc embedded in the material you are about to cut.
5. Check that all accessories, tools etc., that have been used to set the machine up, are removed and set carefully aside or stowed away correctly.
6. Ensure the machine is switched off. Plug the power cable into a correctly rated switched socket outlet. If extension leads are being used, check these for damage, do not use if damaged; if you are working outside, check that any extension cables in use are rated for outside work. Switch on. Allow the saw to run up to speed.
7. Make sure that the material you are about to cut is within the machine capacity, and the cut you are about to make is within the blades' capabilities, e.g. don't try and cut a 1" radius curve using a 5/8" blade.
8. Make sure the blade is not in contact with the material when you start the saw. Start the cutting operation. Do not try to cut too quickly; the correct cutting speed, if one could be so precise, would never see the blade pushed back against the thrust bearing, the saw would cut and clear the saw line at the rate the workpiece was fed into it. If you notice that you require more and more pressure to effect the cut, and the blade is in continual contact with the thrust bearing, the chances are the blade is becoming blunt. Check and change if necessary. Do not let go of the workpiece, if you have to change your grip, make sure one hand is holding the material at all times.
9. If you are cutting long pieces of material think about sawing cutouts (i.e. a saw cut from the edge of the material to the saw line) along the saw line so that you can discard the offcuts as you progress down the saw line.
10. Observe the old woodworkers' adage of never allowing your hand/fingers within one handbreadth of the blade.
11. If you have to cut very small pieces of material, arrange or manufacture some form of 'shoe' to carry the timber. If the workpiece is exceptionally small, find something to use as a sacrificial carrier and mount the workpiece on it with double sided tape, or similar.
12. Remember to check the blade tension after a new blade has been 'working' for 30-60 mins. The blade will 'stretch' slightly when new.

## What's in the Box?

Quantity	Item	Model Number
1 No.	Bandsaw	MT343B
1 No.	Bandsaw blade	
	2240mm long 4 TPI Skip assembled in the saw...(not tensioned)	
1 No.	Saw table	
1 No.	Fence Guide	
1 No.	Mitre Guide	
1 No.	Packet containing the On/Off Switch safety shroud	
1 No.	Table Insert	
1 No.	Floor Stand Kit comprising:-	
	4 No. Legs	
4 No.	X-Ties (2 long, 2 short)	
1 No.	Packet containing	
4 No.	M8*40mm Hexhead Bolts, Nuts and washers (to secure bandsaw to stand)	
24 No.	M8*15mm Roundhead bolts, Nuts & washers (to assemble floor stand)	
1 No.	Instruction Manual	
1 No.	Guarantee Card	

Having unpacked your accessories(see overleaf) please dispose of any unwanted packaging properly. The cardboard packaging is biodegradable.



**Please read the Instruction Manual prior to using your new machine; as well as operating procedures for your new machine, there are numerous hints and tips to help you to use the machine safely and to maintain its efficiency and prolong its life. Keep this Instruction Manual readily accessible for any others who may also be required to use the machine.**

## General Instructions for 230v Machines

### Good Working Practices/ Safety

The following suggestions will enable you to observe good working practices, keep yourself and fellow workers safe and maintain your tools and equipment in good working order.



**WARNING!! KEEP TOOLS AND EQUIPMENT OUT OF THE REACH OF YOUNG CHILDREN**

### Mains Powered Tools

#### Primary Precautions

These tools are supplied with a moulded 13 Amp. plug and 3 core power cable. Before using the tool inspect the cable and the plug to make sure that neither are damaged. If any damage is visible have the tool inspected/repaired by a suitably qualified person. If it is necessary to replace the plug, it is preferable to use an 'unbreakable' type that will resist damage on site. Only use a 13 Amp plug, and make sure the cable clamp is tightened securely. Fuse as required. If extension leads are to be used, carry out the same safety checks on them, and ensure that they are correctly rated to safely supply the current that is required for your machine.

### Work Place/Environment

Make sure when the machine is placed that it sits firmly on the floor, that it does not rock, that it is sufficiently clear of adjacent obstacles so that cutting operations will not be impeded. Check you have adequate clearance both in front of, and behind the machine when cutting long stuff. If you are liable to be processing unwieldy or awkward work pieces, it is suggested that you consider fastening the machine down to the floor.

The machine is not designed for sub-aqua operation, do not use when or where it is liable to get wet. If the machine is set up in the open, and it starts to rain (unusual though this would be in U.K.), cover it up or move it into the dry. If machine has got wet; dry it off as soon as possible, with a cloth or paper towel. Do not use 230Va.c. powered machines anywhere within a site area that is flooded or puddled, and do not trail extension cables across wet areas. Keep the machines clean; it will enable you to more easily see any damage that may have occurred. Clean the machine with a damp soapy cloth if needs be, do not use any solvents or cleaners, as these may cause damage to any plastic parts or to the electrical components. Keep the work area as uncluttered as is practical, this includes personnel as well as material.



**(Under no circumstances should CHILDREN be allowed in work areas).**

It is good practice to leave the machine unplugged until work is about to commence, also make sure to unplug the machine when it is not in use, or unattended. Always disconnect by pulling on the plug body and not the cable. Once you are ready to commence work, remove all tools used in the setting operations (if any) and place safely out of the way. Re-connect the machine.

Carry out a final "tightness" check e.g. guide fence, table tilt, etc..., check that the 'cutting path' (in this case; the path that the work piece will travel) is unobstructed.

Make sure you are comfortable before you start work, balanced, not reaching etc..

If the work you are carrying out is liable to generate flying grit, dust or chips, wear the appropriate safety clothing, goggles, gloves, masks etc., and if the work operation appears to be excessively noisy, wear ear-defenders. If you wear your hair in a long style, wearing a cap, safety helmet, hairnet, even a sweatband, will minimise the possibility of your hair being caught up in the rotating parts of the tool, likewise, consideration should be given to the removal of rings and wristwatches, if these are liable to be a 'snag' hazard. Consideration should also be given to non-slip footwear, etc..

**Do not work with cutting tools of any description if you are tired, your attention is wandering or you are being subjected to distraction. A deep cut, a lost fingertip or worse; is not worth it!**

**Do not use this machine within the designated safety areas of flammable liquid stores or in areas where there may be volatile gases. There are very expensive, very specialised machines for working in these areas, THIS IS NOT ONE OF THEM.**

Check that blades are the correct type and size, are undamaged and are kept clean and sharp, this will maintain their operating performance and lessen the loading on the machine.

Above all, **OBSERVE....** make sure you know what is happening around you, and **USE YOUR COMMON SENSE.**

Undo the nuts out to their maximum, and position them in the 'T' slot in the fence such that they fit into the two slots in the bracket, slide the fence backwards or forwards, to the position you require, then tighten the nuts to hold the fence securely, (ensure that the washers are under the nuts and not on the other side of the bracket). Check the fence is square to the table surface using a reliable square. If the fence is out of square to the table, it can be adjusted using the 'star' bolt (see fig 7) that is threaded through the fence bracket, between the fixing bolts. Remember to loosen the fixing bolts before you adjust the 'star' bolt, then re-fasten. Continue the adjustment until the fence is upright. Check that the fence is parallel to the blade by clamping the fence alongside one of the table slots and compare the parallel. If there is a discrepancy between the two, adjust the Fence Guide Rail by loosening the 4 butterfly bolts that secure the guide rail to the table, adjust, tighten, check; repeat until the fence is parallel. (Note. The fence can be fitted to either side of the bracket; however, the adjusting 'star' bolt will need to be removed and inserted from the other side of the bracket body).

### Setting the blade guides

Lower the upper blade guide ( see fig 1) to approximately 1 1/2" (38mm) above the table. Clamp in place. Loosen the two bolts marked 'A' (see fig 10) holding the guide assembly in place and adjust the back to front position so that the leading edges of the side guide bearings are approximately 1.5 mm behind the gullets of the saw blade. Re-tighten the bolts. Loosen the cross point screw (see fig 9) in the rear bearing clamp and adjust the thrust bearing to approximately 1mm behind the blade, tighten the screw. (Note that the rear thrust bearing is mounted on a 'cranked' arm which can pivot; ensure that when you clamp the arm in position, the blade is running approximately midway between the centre and the outside edge of the bearing). (Check the symmetry with the bottom thrust bearing).? Loosen the two bolts (marked 'B' fig 10) holding the guide bearings (10mm spanner) and move to approximately 0.5 mm from each side of the blade. Tighten the bolts. Gently push the blade back against the thrust bearing (use a scrap of wood, et al.) and check that the side bearings are still behind the teeth of the blade. Loosen the bolt (bolt 'C' fig 12) holding the lower blade guide assembly in place and position similarly to the upper guide assembly. Tighten the bolt. Loosen the clamping screw (screw 'D' see fig12) of the rear thrust bearing (cross point screwdriver). Move it forward until it touches the back of the blade; gently push the blade back against the upper thrust bearing, this should move the lower thrust bearing back in line with upper bearing; tighten the clamping screw. Adjust the lower side blade guides, and set them similarly to the upper guides, using a cross point screwdriver to release and tighten the clamping screws ( marked 'E' fig 12). s(You may find it easier to adjust the lower guide assembly if you remove the plastic safety box that is screwed to the lower guide mounting. Remove by unfastening the screw shown in (fig.11). Replace after all adjustments have been made. When all adjustments have been made, recheck that when the blade is pressed back against the thrust bearings, both the upper and lower side guides are still behind the teeth of the saw. (This is imperative in the case of the lower guides as these are steel rods, and if they impact with the saw teeth..... I leave it to your imagination.). When all adjustments are complete replace the table insert. Re-connect the power, switch the saw on, allow to run for several minutes, check that the blade is still tracking correctly, there is no excessive vibration, etc., etc. Switch off. The saw is ready to be used. Now please read the Instruction Manual.

### DO NOT CONNECT THE SAW TO THE MAINS POWER SOURCE.

#### Tensioning and tracking the blade

Make sure both top and bottom blade guides are well clear of the blade.

Open the front covers fully, giving good access to the top compartment of the saw (see fig 4) and good visibility into the bottom compartment (see fig 5). Check that the blade is sitting approximately in the middle of the wheels. Apply some tension to the blade by turning the tensioning wheel clockwise, spin the top wheel and check that the blade remains centrally on the tyre, if it does not, adjust the tracking by turning the tracking control at the rear of the head box (see fig 4). (Viewed directly onto the tracking control wheel, turning clockwise should cause the blade to track to the rear of the tyre, anti-clockwise to the front, DO NOT make large adjustments). Spin the top wheel again, check again. Continue until the blade tracks in the centre of the tyres with no appreciable to and fro movement. Tension the blade fully. (A side ways push of about 7-8 lbs(3+kgs) in the middle of the blade should allow a 1/4", (6.5mm) distension). Check the tracking again, adjust if necessary. Check that the drive belt is tensioned correctly, if it is slack, apply 'take up' pressure to the belt by adjusting the 'idler' pulley, using the knob at the side of the machine. (See fig 5). Connect the power to the machine. Stand clear and start the saw, check that the saw is running smoothly, (no thumps, bumps, knockings or excessive vibration) and the blade appears to be tracking correctly (in one place). You can check this by holding a marker, e.g. a pencil, close to the back of the blade (approach from the back of the blade only) and check that the gap remains constant. If it doesn't, adjust the tracking until it does. (If you adjust the tracking with the saw running, make very small adjustments and wait for the saw to react before you adjust again, sometimes the reaction is not instantaneous). Once you are satisfied that the tracking is correct switch the machine off and allow it to run to a stop.

### DISCONNECT FROM THE SUPPLY.

#### Checking the table is square

Loosen the butterfly nut clamping the tilt mechanism, and turn the table hard against its stop. (This is a bolt with a lock nut screwed into the underside of the table, (see fig 6), the head of the bolt acts as a stop when it strikes the machine frame). Tighten the butterfly nut. Make sure the upper blade guide is raised as high as possible. Place a square on the table and move it up against the blade (behind the teeth). Check that the blade is perpendicular to the table. If it is not, try resetting the table. If it is still not correct, loosen the locking nut and adjust the bolt until perpendicularity is achieved, tighten the lock nut and then re-check. When you are satisfied that the table is set correctly, check that the pointer of the tilt gauge reads zero, if not, adjust it.

#### Setting the Fence

The fence is usually supplied in two pieces, the bracket and the fence itself. The clamping arrangement for the bracket consists of a coach bolt, an oblong plate and a butterfly nut, these items are usually pre-positioned in the bracket. To mount onto the machine, loosen the butterfly nut to its maximum, pull the bolt back out of the bracket, position the oblong plate with the longest sides horizontal, and fit the square hole over the square on the underside of the bolt head. Introduce the oblong plate into the 'T' slot cavity in the front of the Fence Guide Rail, such that the bolt is positioned in the slot, and the bracket can be slid side to side along the front of the table. Note. There are two location lugs cast on the rear of the bracket, these should fit into the same slot as the bolt, to prevent the bracket twisting. Clamp the bracket by tightening up the butterfly nut. The fixing arrangement for the fence consists of two small coach bolts, with washers and 'thumb' nuts, usually pre-positioned in the 'T' slot of the fence extrusion (see fig 7).

Your saw is packed in the box partially assembled. Unfortunately this is more of an exercise to ensure that the components are inserted in the correct positions than a shortening of the build time. e.g. the blade is fitted, the securing bolt for the tilt mechanism is inserted in the tilt quadrant with the washer and the locking butterfly nut threaded on to the bolt, etc..

Please make careful note of the positions of the various components if you have cause to disassemble, whilst putting the machine together. ( Now there's an oxymoron)

Take all the easily removable items out of the box, tip the box up so that the base of the saw is to the ground, remove all the polystyrene packaging from around the saw (open both sides of the box?) then "corner walk" the saw out of the box. If this is still awkward, split the top of the box, fold the box material flat on the floor, and "wriggle" the saw off the cardboard. (The best method of moving the saw is with a 'hug' lift through the neck of the saw, holding the saw back against your body and lifting by straightening your legs).

#### Assemble the floor stand as follows:-

Remove the pre-assembled M8x15 bolts, nuts and washers from the packet, remove the nuts and the washers, separate into different piles, put close to hand. Match the long and the short X-ties of the stand and select either pair. Take one of the legs and bolt one of the X-ties to it, (the X-ties go on the inside of the leg ), insert a bolt from the outside of the leg, through the X-tie, fit the washer and the nut, (at this stage do not tighten any of the nuts and bolts), bolt another leg to the other end of the X-tie following the same procedure. Fit the other X-tie with the other two legs, and then join these two assemblies together using the other paired X-ties. When all is assembled, ensure the floor stand is on a flat surface and tighten up all the nuts and bolts. (You will need a 13mm spanner and a large X-point screwdriver). Assemble the 4 rubber pad feet to the bottoms of the legs.

#### Assembling the Saw

Lift the saw on to the completed floor stand, and secure using the 4 No. M8x40 bolts. ( Insert the bolts through the base of the saw, through the floor stand and fit the washers and nuts on the underside). The saw table can be fitted without removing the blade, however, if you would feel more comfortable not having to manoeuvre the table around the blade (the table is quite heavy), remove the blade by opening the top and bottom covers, release the tension on the blade by backing off the tensioning wheel (See fig 3), and remove the blade, taking care as it is manoeuvred clear of the guides and the safety guards.

Preparing the saw table for fitting:-

- 1.Remove the guide fence rail by loosening the 4 No. butterfly bolts holding it to the front of the table. Remove the table insert.
3. Put a small pencil 'X' on the front of the tilt quadrant body. (It will save you working out which way round it fits). Turn the table upside down, locate the 4 No. bolts securing the tilt quadrant to the table, loosen and remove them and their washers, (you will need an 11mm spanner). Lift the tilt quadrant away from the table. Note. There are normally spacing washers fitted between the table and the feet of the tilt quadrant. Don't loose them.
4. The securing bolt for the tilt mechanism (an M8x50 coach bolt) is pre-fitted into the tilt quadrant. Remove the butterfly nut and the washer and fit the tilt quadrant into the tilt housing. Ensure that the bolt is correctly inserted through the slot and that the little rib cast on the tilt housing corresponds to the groove in the tilt quadrant. Check that the square under the bolt head is correctly located in its recess in the casting and refit the washer and the butterfly nut. Before tightening, check that the tilt mechanism functions correctly. If it doesn't, something is probably slightly mis-aligned, slacken off the butterfly nut, re-position the quadrant and try again. When everything is satisfactory, set the tilt quadrant so that the mounting feet are horizontal and tighten.
5. Place the 4 spacing washers over the holes in the tilt quadrant feet and lift the table into position. Insert the washered bolts through the feet, the spacing washers, and screw into the table. (As you insert each bolt and establish a turn or turn and a half into the table I would suggest you leave the bolts as slack as possible to enable you to manoeuvre the table around to achieve the fitting of the other bolts). Make sure that you don't displace the spacing washers during this manoeuvring. When all the bolts are inserted, tighten firmly. **DO NOT OVER -TIGHTEN.** Remember this is a casting, if you drastically over-tighten you could strip the threads.

## Initial Assembly (Continued)

6. Replace the blade, slipping it through the slot in the table, through the guards and the guides and over the wheels; apply some tension to the blade to hold it in place. Replace the guide fence rail.
7. If you wish to be able to isolate the saw physically, to prevent unauthorised or unsupervised usage, a switch shroud is provided. The shroud and the integral dust cover are fitted over the On/Off switch and secured with two small screws through holes in the outer bezel of the switch plate. It is suggested that you mount the shroud so that the cover hinge is at the top, i.e. the cover pivots upward. Although when the hinge becomes more flexible, this sometimes requires the cover to be lifted out of the way to operate the ON button; in an emergency, a quick slap of the hand will close the cover and switch the machine Off. With the cover closed a small padlock can be fitted to prevent the cover being lifted and access to the ON button is denied.



**Please note the assembly instructions below refer only to the CCBB II**

### Fitting the Guide fence assembly for the CCBB II

1. Remove the current guide fence and the fence rail.

The back rail needs to be mounted on the rear of the table by drilling and tapping 3 holes. This can be done with the table in situ. Looking from the rear of the machine, mark out the three hole centres as follows:-

All holes are 7mm up from the lower edge of the table.  
All distances are from right hand edge of the table.

- Hole 1 . 30mm**
- Hole 2. 240mm**
- Hole 3. 470mm**

**NOTE: The 'out of centre' measurement for Hole 2 is to ensure the hole misses the web re-enforcement of the table.**

Centre punch these centres and drill through with 5mm drill. Tap M6.

2. Assemble the back rail to the rear of the table by inserting the M6 bolts and washers, through the predrilled holes in the extrusion. Because of the off-centre hole the back rail cannot be fitted the 'wrong' way. (See fig 1)

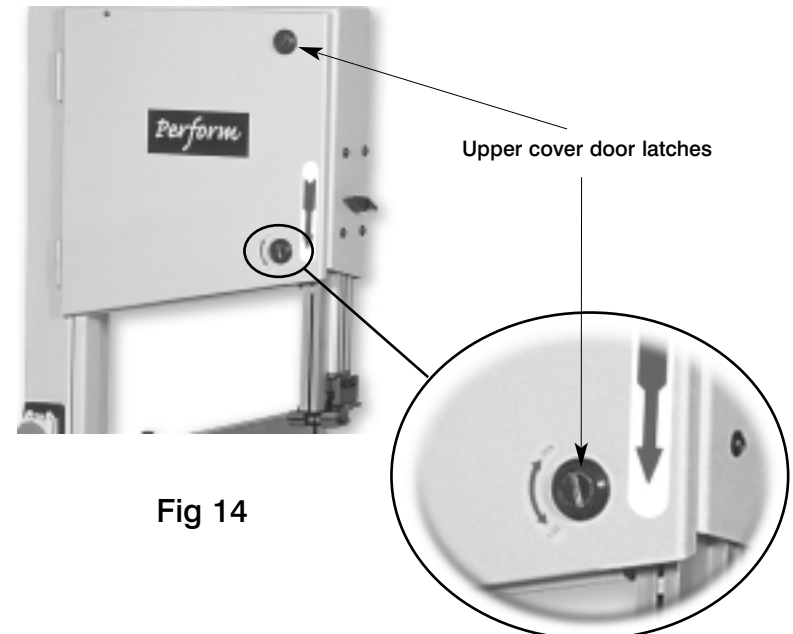
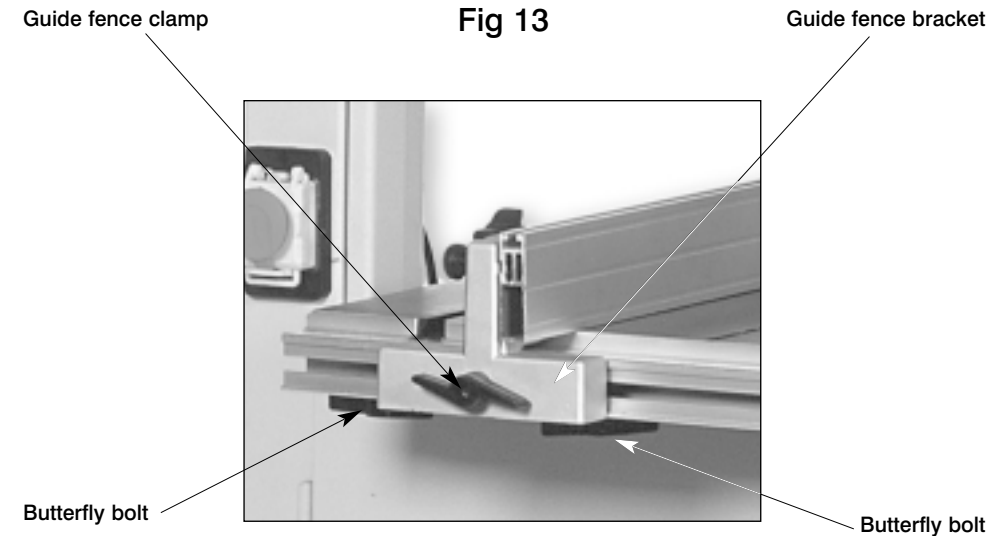
Using the four bolts and washers supplied to mount the (original) fence rail, mount the (upgrade) fence rail by sliding the tongue under the edge of the table with the cut-outs about the bolts, above the washers. Introduce until fence rail body is against the edge of the table. (See fig 1a) Tighten the 4 bolts securely.

**(DO NOT OVERTIGHTEN, remember this is a casting, over-tightening could cause the threads to strip).**

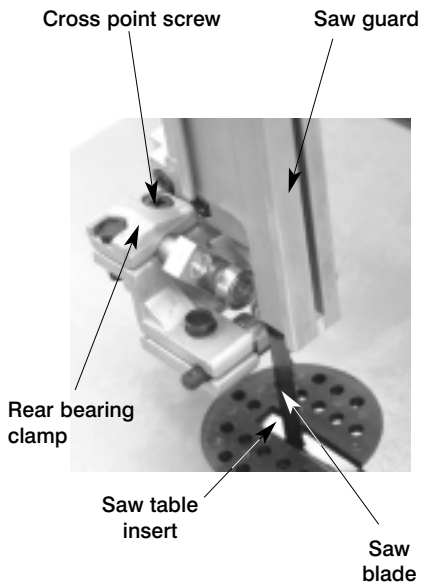
Fit the guide fence by clipping the rear clamp over the back rail first and dropping the front clamp over the fence rail. (See fig 2a) Push down on the lock lever, and ensure the fence clamps up correctly. (See fig 2d) If not, adjust the clamping system by tightening or loosening the nut on the end of the torsion rod at the rear end of the guide fence blade. (See fig 2b)

Check the guide fence is set parallel to the blade. Any slight discrepancy can be taken out by loosening the 4 No. caphead bolts that secure the blade of the guide fence to the clamping body, adjust and re-tighten. Larger discrepancies may require that the fence rail is angled slightly. The dimensioning scales have adjustable index plates set in the fence guide front clamp body to enable the scales to be zero read. (See fig 2c)

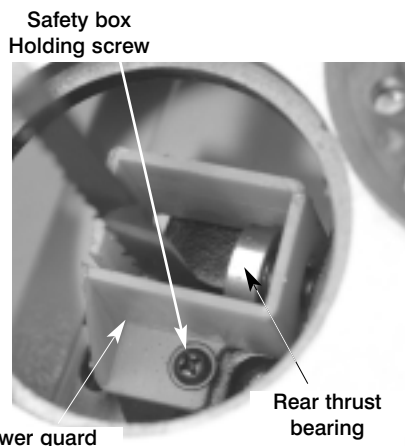
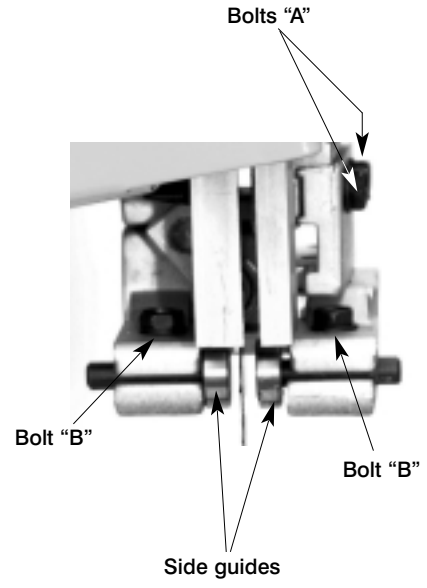
## Machine Illustration and Parts Description (Continued)



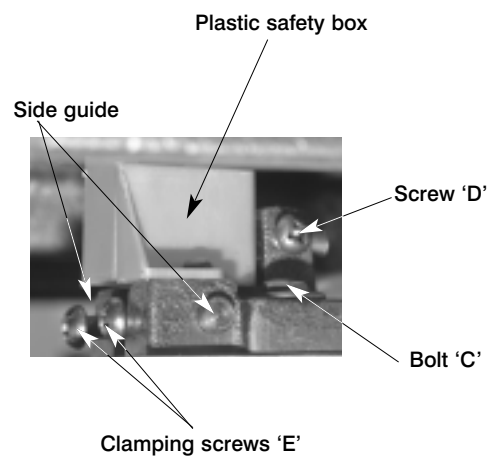
**Fig 9**



**Fig 10**



**Fig 11**

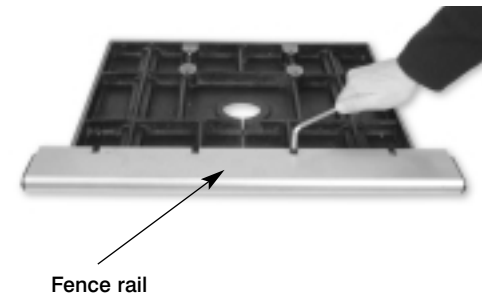


**Fig 12**

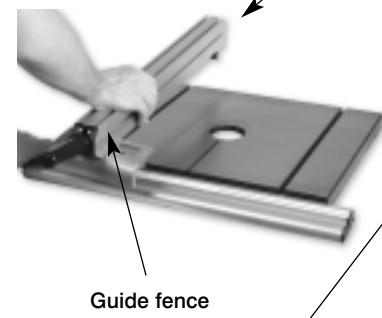
**Fig 1**



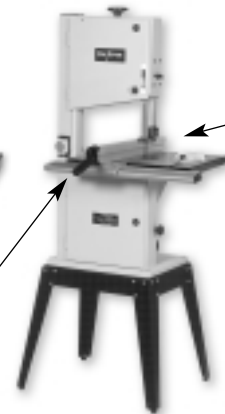
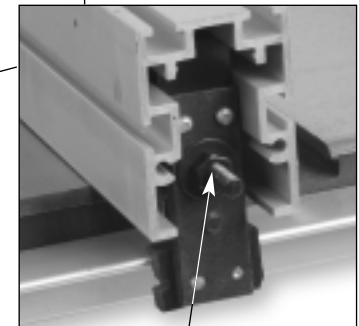
**Fig 1a**



**Fig 2a**

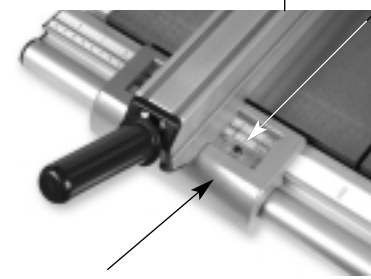


**Fig 2b**

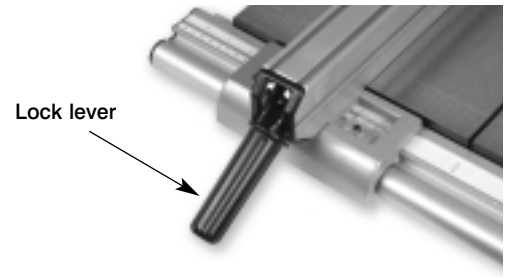


**Fig 2**

**Fig 2c**



**Fig 2d**



Dimensioning scale

**Please note the assembly illustrations above refer only to the CCBB II**

## Machine Specifications

Axminster No:	CCBB	Rated	Hobby
Motor	230V a.c, 50Hz, 1448 rpm, 550W		
Wheel Diameter	315mm		
Blade Speeds (Off Load)	360 M/mm 720 M/mm		
Max Cutting Depth.(Throat) (Upright)	160mm		
Max Reach (Neck) (Table Flat)	300mm		
Blade Length	2240mm		
Blade Widths	3/8" to 5/8"		
Table Tilt	Right 0-45 degrees		
Weight	80 kgs		
Overall size (On Floor Stand)	Height 1550mm, Width 650mm, Depth 400mm		
Dust Extraction Nozzle Diameter	100mm		
Supplied Cable Length	2 Metres		

## Identification and Description of the parts of the Saw

**Main saw frame** The main body of the machine that all the other parts are mounted upon. (See fig 3)

**Upper and lower cover doors** The two doors that cover the upper and lower saw wheel compartments. There are interlocks fitted to both doors so that the machine cannot operate if either door is left open. (See fig 3)

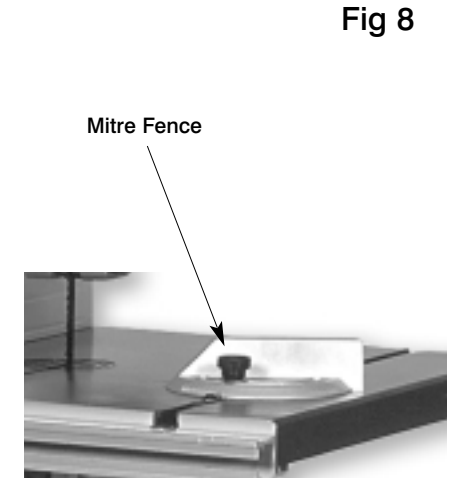
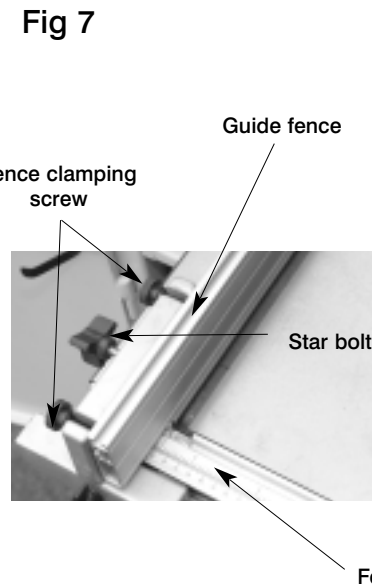
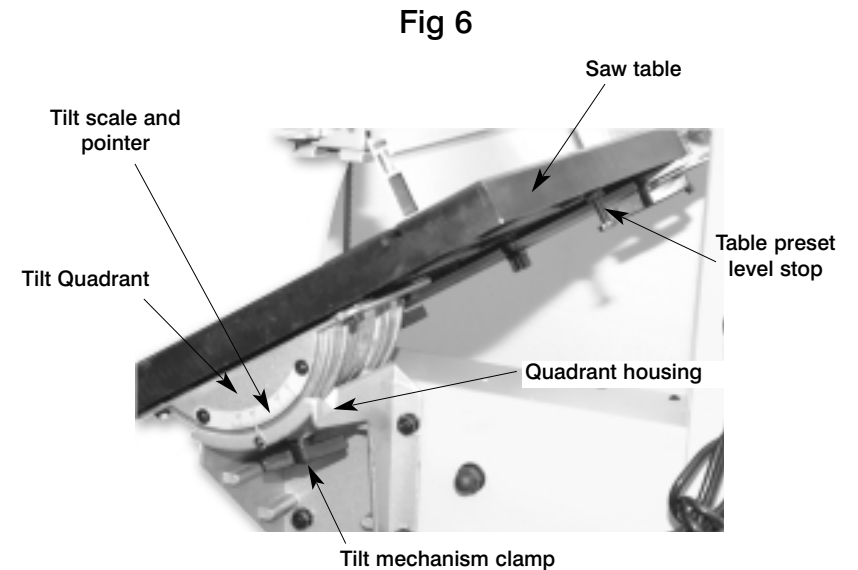
**Upper saw wheel** The upper saw wheel is mounted on double bearings on an axle that is mounted to a tilting plate. (To provide the fore and aft tilt movement that controls the blade tracking). The tilting plate is hinged to a base plate that is mounted in slides in the upper saw wheel compartment. (The base plate slides up and down allowing increasing or decreasing of the blade tension). The saw wheel is fitted with a rubber tyre to give better grip to the saw blade, and smoother running. It also allows the blade to be tracked in the centre of the wheel; unlike the bad old days when the blade had to be tracked off the front edge of the wheel to safeguard the teeth. (See fig 4)

**Blade tensioning wheel** The blade tensioning wheel, at the top of the machine, is connected to a threaded rod that is engaged in the base plate of the upper saw wheel axle assembly. The threaded rod is anchored in the top of the saw frame which allows the base frame to be driven up and down in its mounting slides and tension or de-tension the blade. (See fig 4a)

**Upper blade guide and guard** The upper blade guide assembly mounts the two side bearings and the rear thrust bearing that keep the blade stable (straight and untwisted) above the table during the sawing operation. The guard is an integral part of the guide mounting leg to which the guide assembly is bolted so it is always in place when the guide is raised or lowered to its working position. (See fig 3)

**Upper blade guide height clamp** The upper blade guide height clamp is a butterfly nut and coach bolt arrangement that clamp through the guide mounting leg and the main saw frame. So, loose it will allow the mounting guide leg to be moved up and down, tightened it will clamp the leg in position against the frame. (See fig 4a)

## Machine Illustration and Parts Description (Continued)





## Identification and Description of the parts of the Saw (Continued) Saw

**Tracking control star knob**  
(See fig 4a)

The tracking control star knob, at the rear of the top compartment, is connected to a threaded rod that is engaged in a threaded hole in the base plate of the upper saw wheel axle assembly. The end of the rod pushes against the lower end of the hinged tilting plate that carries the upper saw wheel axle. Driving the rod in or out will cause the plate to tilt, and by association, the upper saw wheel, thus enabling the blade to be 'tracked'. The tilting plate is kept in contact with the end of the threaded rod by the tension on the saw blade, (the downward 'pull'). It should be self-evident therefore, that the blade can only be 'tracked' whilst it is in tension.

**Lower saw wheel**  
(See fig 5)

The lower saw wheel and integral pulley wheel is likewise mounted on double bearings, onto an axle that is mounted to a fixed base plate. The base plate, triangular in shape, is bolted to the rear face of the lower saw wheel compartment. There are no adjustment mechanisms for the lower saw wheel. Mounted on a fixed shaft on a fixed base it is the base parameter that the rest of the saw is set against.

**Drive belt tensioning idler wheel**  
(See figs 4 & 4a)

The drive belt tensioning idler wheel (the idler), is mounted on a stub axle assembly that is captive in a slotted base plate. The Idler Wheel adjusting knob, on the side of the lower saw wheel compartment, is connected to a threaded rod which is engaged in the stub axle assembly. The rod is anchored in the side of the main saw frame, so that turning the knob will drive the stub axle assembly back and forth along the slot in the base plate. This allows the drive belt to be tensioned, or the tension removed to allow the belt to be changed or moved to the alternate groove to change the speed. Remember; the belt is tensioned by 'pushing' the idler forward against the belt, not 'pulling' the idler back against the belt.

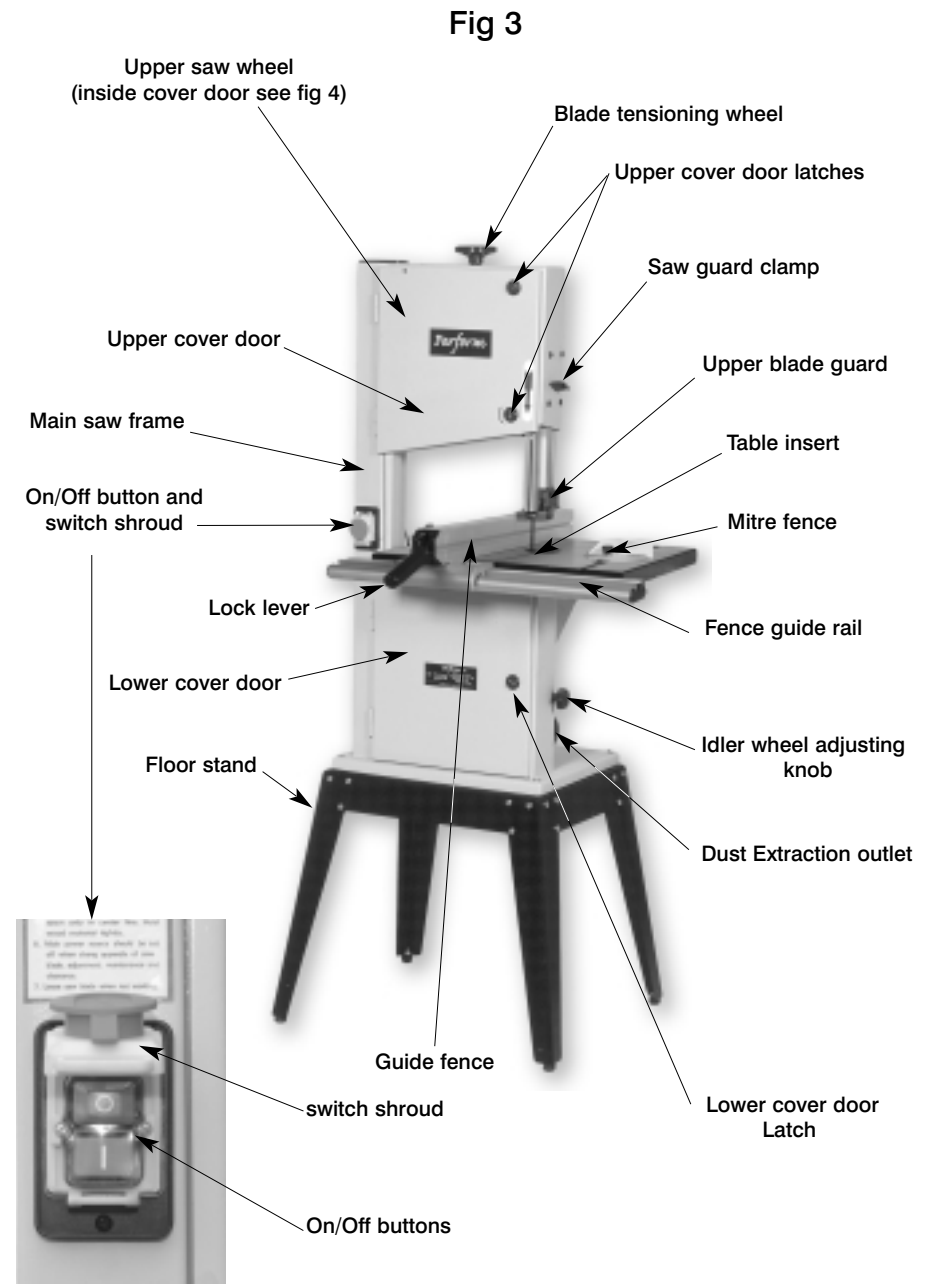
**Dust extraction outlet**  
(See fig 3)

A 100mm diameter dust extraction outlet.

**On/Off Button and switch shroud**  
(See fig 3a)

The On/Off buttons, fitted with the optional shroud, (see the initial assembly instructions).

## Machine Illustration and Parts Description



**Fig 3a**

## Identification and Description of the parts of the Saw (Continued)

<b>Saw table, tilt assembly and scale</b> (See fig 6)	The saw table is mounted on the tilt quadrant, which is, in turn mounted in the quadrant housing and secured via a coach bolt and butterfly nut arrangement. Loosening the butterfly nut allows the table to be tilted up to 45 degrees clockwise. There is an adjustable bolt with a lock nut, screwed into the underside of the table, which acts as a pre-set stop when bringing the table back to the level position. There is a scale and pointer attached to the rear of the quadrant and the housing to measure the angle to which the table has been tilted. There are two slots machined in the table to accept the slide of the mitre fence.
<b>Saw table insert</b> (See fig 9)	The saw table insert fits into the round recessed groove in the centre of the table. It not only fills the round void, it also supports the workpiece below the saw in order to minimise 'breakout' from the sawcut. The table insert that is supplied is for general work, and as such has a fairly wide slot, to allow the fibre strands from general redwoods and whitewoods to be carried through by the saw blade. Alternative table inserts should be made when carrying out very fine work, where the breakout must be kept to a minimum.
<b>Lower blade guide and guard</b> (See figs 10 & 11)	The lower blade guide assembly is mounted on the main saw frame below the table, it mounts the rear thrust bearing and two side guide rods that keep the blade stable (straight and untwisted) below the table during the sawing operation. The lower guard is a red plastic enclosure that screws to the guide assembly, and shields the blade between the underside of the table and the top of the lower saw wheel compartment.
<b>Fence guide rail</b> (See fig 13)	The fence guide rail is a metal extrusion that is bolted onto the saw table with 4 butterfly bolts and washers. The fixing locations in the guide rail are slots, which allow the angle of incidence between the table and the guide rail to be adjusted; to enable the guide fence to be set square to the table. There is a ruler scale set in the guide rail to aid the setting of the guide fence.
	<b>NOTE. The guide fence rail should always be fitted and securely fastened to the saw table, even if it is not properly set up for the fence. This is to help maintain the stability of the saw table in the area of the slot which is cut through the table to allow the blades to be fitted.</b>
<b>Guide fence</b> (See fig 2a)	An extruded aluminium assembly primarily consisting of the main mounting body and the blade. The blade is bolted to the top of the main body. The main body is shaped to fit over the fence rail and mounts the clamping handle. The clamping handle is attached to a torsion bar which is fed through the blade of the guide and acts on the rear clamp, pulling it tight against the back rail through the lever action of the clamp handle. There is a fixed measurement scale mounted on the fence rail. On each side of the main body is an aperture through which this scale can be read. Mounted in each aperture is an adjustable index, to enable the measurements to be zeroed.
<b>Mitre fence</b> (See fig 8)	The mitre fence slide can be engaged in either of the slots in the saw table, and acts as an X-feed device, which will enable any angle from 0 to 45 degrees left or right to be cut with the saw.
<b>Back Rail</b> (See fig 1)	An aluminium extrusion bolted to the rear of the saw table, that is used as the rear clamp bracket for the guide fence.

## Illustrated Parts Catalogue (Band Saw) Part 2

NO.	name	Qty	NO.	name	Qty
93	graduate disc	1	115	thumb bolt	4
95	rolling fixed frame	1	116	hexagon nut M6	6
97	hexagon nut M8	5	117	protect board	1
98	drawing belt	1	118	spring washer ø12	3
99	circlips for shaft	1	119	spring washer ø8	8
100	bearing 80101	2	120	spring	1
101	press wheel	1	121	key 5x25	1
102	axle of press wheel	1	122	plastic bush	B(4)C(3)
103	press wheel pole	1	123	fix bush	1
104	spring pin	1	124	lock nail M6x12	1
105	handle of press wheel	1	125	flat nail M5x6	1
106	hexagon screw M6x18	1	126	semicircle head screw M6x20	1
107	flat screw M6x18	1	127	plastic square washer	1
108	upper press board	1	128	external teeth washer ø4	6
109	bearing parts for spacing	1	129	washer ø4	9
110	hexagon screw M6x20	2	130	flower knob	1
111	bearing pole	2	131	semicircle head screw M4x30	8
112	guide frame stand	1	132	interlock switch	2
113	single hole press board	2	133	hexagon nut M4	4
114	hexagon screw M6x12	2			

NO.	name	Qty	NO.	name	Qty
1	column cover	1	45	double-ended screw	3
2	sawing body	1	46	big triangle frame	1
3	copper washer	4	47	rubber belt for saw wheel	2
4	magnetic switch	1	48	semicircle head screw M5×12	1
5	hexagon head screw M8×20	4	49	washer ø10	1
6	motor	1	50	semicircle head screw M6×12	5
7	dust cover	1	51	frame of guide pole	1
8	upper door	1	52	guide pole	1
9	lower door	1	53	spacing board	1
10	thin hexagon head screw nut	B(4)C(3)	54	tapping screw ST4.8×15	4
11	door rolling axis	B(4)C(3)	55	square-necked screw M8×24	5
12	curved spring washer	B(4)C(3)	58	square pole end frame	1
13	case of door rolling axis	B(4)C(3)	59	long hole center seat	1
14	closing door board	B(4)C(3)	60	washer f 6	B(14)C(13)
15	flat head screw M6×8	B(4)C(3)	61	hexagon head screw M6×24	3
16	semicircle head screw M5×8	6	62	bearing 80016	4
17	washer ø5	5	63	semicircle head screw M4×6	1
18	spring leaf	2	64	small safety cover	1
19	hexagon nut M5	2	65	stop axis pole	1
20	hand wheel	1	66	guide axle	2
21	semicircle head screw M6×16	1	67	semicircle head screw M6×14	2
22	washer ø12	4	68	nut board	1
23	guide screw pole	1	69	guide frame	1
24	spring	1	70	screw dowel	1
25	square nut	1	72	hexagon head screw M6×14	2
26	steel dowel	2	73	thumb nut M8	3
27	guide board saddle	2	74	stand of upper guide board	1
28	washer ø8	18	75	stripe-shaper washer	2
29	hexagon head screw M8×16	4	76	step bolt M8×50	2
30	upper wheel saddle	1	77	flower nut	2
31	small triangular frame	1	78	step bolt M6×40	2
32	upper wheel axle	1	79	upper guide board	1
33	adjusting handle M8	1	80	hexagon head screw M8×44	1
34	bearing 80203	4	82	guide board	1
35	upper saw wheel	1	83	worktable	1
36	blade	1	85	board of saw mouth	1
37	axis elastic ring	2	86	large washer ø6	4
38	low saw wheel	1	87	side guide board	1
40	low wheel axle	1	88	rotating angle rule	1
41	hexagon nut M16	1	89	stand of worktable	1
42	lid shape nut	3	90	socket head cap screw M8×20	4
43	motor wheel	1	91	rotating pointer	2
44	washer ø14	1	92	flower knob M6×18	1

